

PRODUCT DATA SHEET

LINE MATCHING TRANSFORMER

P2001

Features

- * Ultra Low Distortion
- * Lead-free (Pb-free)
- * RoHS compliant
- * 12.6mm (0.5") seated height
- * Vacuum encapsulated
- * IEC 60950 and UL 60950 Certified
- * UL Recognized Component

Applications

- * Telecommunications
- * V.34modems
- * Portable computers
- * Fax / modems

DESCRIPTION

P2001 is the transformer of choice in high-speed applications where good performance in a robust resin encapsulated package is required at a most competitive price.

P2001 meets international safety standards, being vacuum encapsulated and 100% tested to withstand 6.5kV DC. The part is completely lead-free, compliant with RoHS Directive 2002/95/EC, and suitable for lead-free and conventional processing.

P2001 is ideal for datacommunications at V.34 (33,600 bits/second) and is a drop-in replacement for industry standard P1200 for circuits to be upgraded for high speed.

P2001 is certified to IEC 60950 and UL 60950. P2001 is a UL Recognized Component and is supported by an IEC CB Test Certificate.

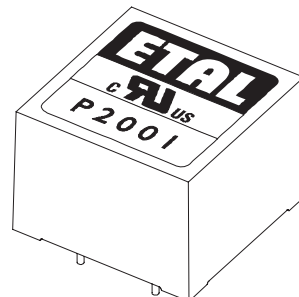

RoHS
COMPLIANT

SPECIFICATIONS

Electrical

At T = 25°C and as circuit fig. 2 unless otherwise stated.

Parameter	Conditions	Min	Typ	Max	Units
Insertion Loss	f = 2kHz, R _L = 560Ω	-	-	1.5	dB
Frequency response	LF-3dB cutoff	-	-	50	Hz
	HF-3dB cutoff	10	-	-	kHz
	200Hz - 4kHz	-	-	±0.2	dB
Return Loss	200Hz - 4kHz	18	-	-	dB
Third Harmonic Distortion ⁽¹⁾	450Hz 0dBm in line	-	-85	-	dBm
	600Hz -10dBm	-	-	-105	dBm
Balance	DC - 5kHz Method TG25	80	-	-	dB
Saturation	Excitation 50Hz 250V rms. Output voltage across line	-	-	10	Vrms
		-	-	65	Vpeak
Voltage isolation ⁽²⁾	50Hz	3.88	-	-	kVrms
	DC	5.5	-	-	kV
Operating range:	Ambient temperature	-25	-	+85	°C
		-40	-	+125	°C
		-	-	95	%R.H.

Lumped equivalent circuit parameters as Fig. 1

DC resistance, R _{DC} ⁽³⁾	Sum of windings	118	-	146	Ω
Leakage inductance ΔL		15	-	19	mH
Shunt inductance L _p ⁽⁴⁾	200Hz 10mV	4.5		15	H
Shunt loss R _p ⁽⁴⁾	200Hz 10mV	14	-	40	kΩ

Notes

1. Third harmonic typically exceeds other harmonics by 20dB.
2. Components are 100% tested at 6.5kV DC.
3. Caution: do not pass DC through windings. Telephone line current, etc. must be diverted using choke or semiconductor line hold circuit.
4. At signal levels greater than 100mV, L_p will increase and R_p will decrease slightly but the effect is usually favourable to the return loss characteristic.

Equivalent Circuit

Fig 1

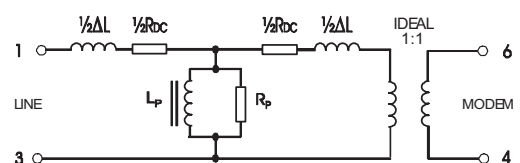

PERFORMANCE CHARACTERISTICS

600Ω MATCH

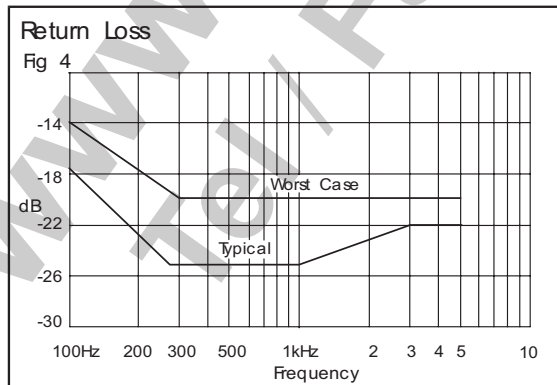
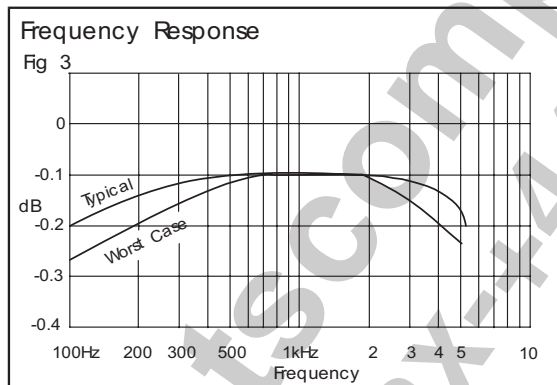
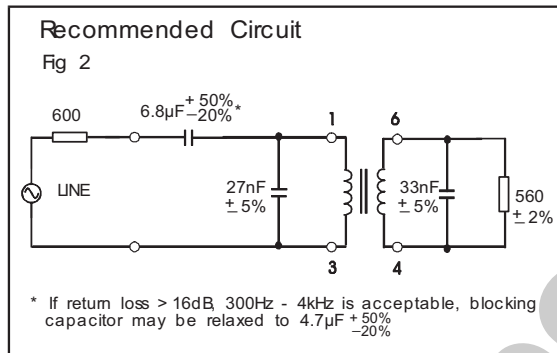

EUROPEAN CTR21 COMPLEX MATCH

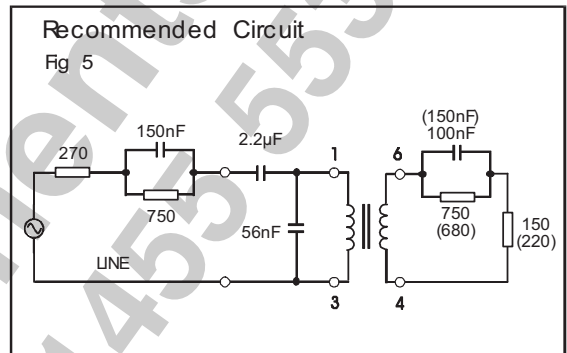
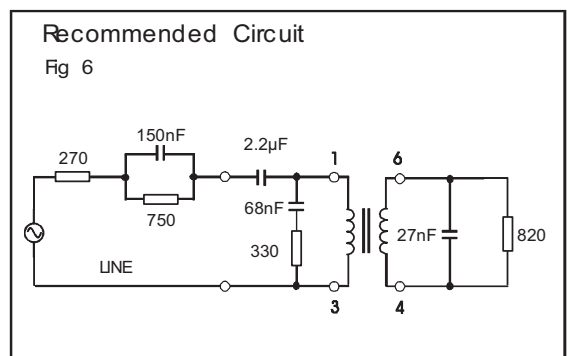
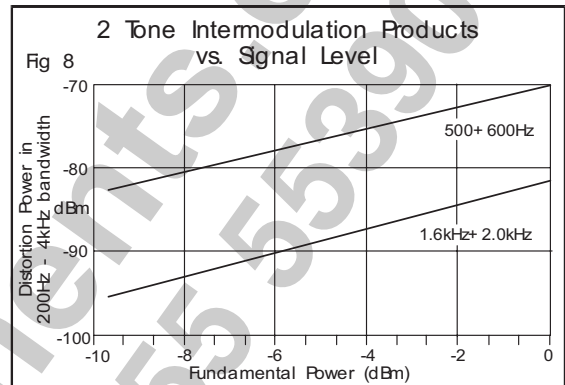
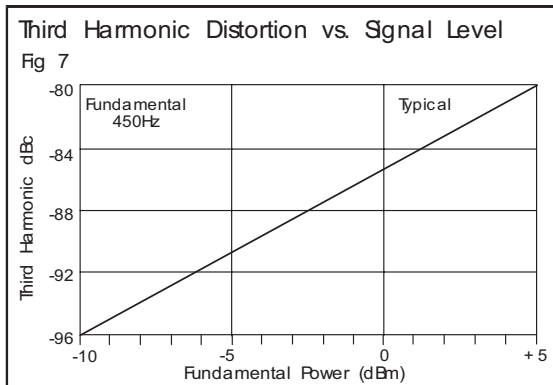

Figure 5 gives flat RX and TX responses against the reference impedance (typically around ± 0.5 dB 300Hz - 3.4kHz). Return loss is typically better than 20dB. The circuit values in parentheses give optimum flatness at a small sacrifice in return loss.

For circuits with existing board drillings, figure 6 gives good return loss (>20dB) and RX flatness against the reference impedance, but TX flatness is degraded by the use of this topology.



PERFORMANCE CHARACTERISTICS



Notes

- Figure 7 - to obtain harmonic distortion power in dBm, add fundamental power in dBm to third harmonic in dBc e.g. at -10dBm power in line at 450Hz third harmonic power is $-10 + (-96) = -106$ dBm typical.
- Third order intermodulation products $2f_a - f_b$ and $2f_b - f_a$ are of most importance and are significantly greater than products $2f_a + f_b$ and $2f_b + f_a$. Figure 8 gives the total power of all distortion products within the voiceband.

CONSTRUCTION

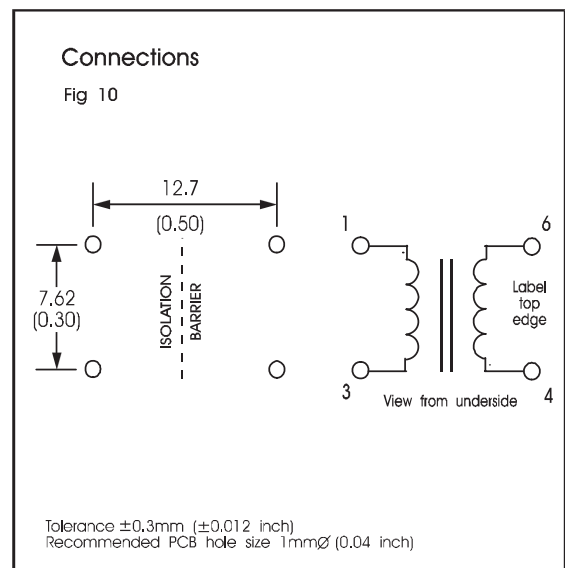
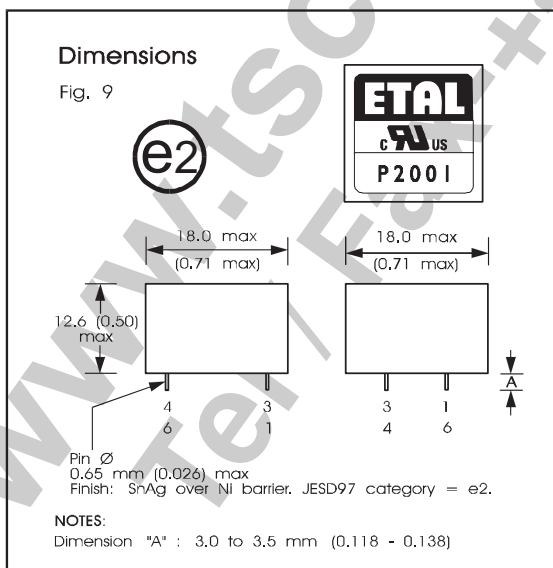

Dimensions shown are in millimetres (inches).
Geometric centres of outline and pin grid coincide within a tolerance circle of 0.6mm
Windings may be used interchangeably as primary or secondary.

SAFETY

Constructed in accordance with IEC 60950-1:2001, EN 60950-1:2001 and UL 60950-1 First Edition, supplementary insulation, 250Vrms maximum working voltage, flammability class V-0. Distances through solid insulation 0.4mm minimum.

CERTIFICATION

Certified under the IEC CB scheme (Certificate DK-9431) to IEC 60950-1:2001, sub-clauses 1.5, 1.5.1, 1.5.2, 1.7, 1.7.1, 2, 2.9, 2.9.1, 2.9.2, 2.9.3, 2.10, 2.10.1, 2.10.2, 2.10.3, 2.10.3.1, 2.10.3.3, 2.10.4, 2.10.5, 2.10.5.1, 2.10.5.4, 4, 4.7, 4.7.1, 4.7.3, 4.7.3.1, 4.7.3.4, 5, 5.2, 5.2.1, and 5.2.2 for a maximum working voltage of 250Vrms, nominal mains supply voltage not exceeding 300Vrms and a maximum operating temperature of 85°C in Pollution Degree 2 environments, supplementary insulation, including national differences for Denmark, Finland, Germany, Norway, Sweden, Switzerland, USA, Canada and UK.

Recognized under the Component Recognition Program of Underwriters Laboratories Inc. to US and Canadian requirements CAN/CSA C22.2 No. 60950-1-03/UL60950-1, First Edition, based on IEC 60950-1, First Edition, maximum working voltage 250Vrms, Pollution Degree 2, reinforced insulation.

UL File number E203175.

Additionally, Profec Technologies certifies all transformers as providing voltage isolation of 3.88kVrms, 5.5kV DC minimum. All shipments are supported by a certificate of conformity to current applicable safety standards.

ABSOLUTE MAXIMUM RATINGS

(Ratings of components independent of circuit).

Short term isolation voltage (15s)	4.6kVrms, 6.5kV DC
DC current	100µA
Storage temperature	-40°C to +125°C
Lead temperature, 10s	260°C

COPYRIGHT

ETAL, P1200 and P2001 are Trade Marks of Profec Technologies Ltd. The Trade Mark ETAL is registered at the UK Trade Marks Registry.

Profec Technologies Ltd. is the owner of the design right under the Copyright Designs and Patents Act 1988 and no rights or licences are hereby granted or implied to any third party.

© 1996 - 2006 Profec Technologies Ltd. Reproduction prohibited.



ISO 9001
FM 25326

ETAL Group Oy, Kuormatie 14, FIN-03101, Nummela
Telephone: +358 (0)20 7500 330 Fax: +358 (0)20 7500 333
Website: www.etalgroup.com Email: etalgroup@egruppen.com